

BUZON PB-Series®

Pedestals adjustable from 28 to 965mm

BUILDING - MERCHANT RETAILER PRICE LIST INTERNATIONAL - Excl. VAT - Ex-factories - Prices valid on 01/02/2014



© COPYRIGHT

BUZON Pedestal International s.a./n.v
Z.I. des Hauts-Sarts, Zone 1 - Prolongement de la rue de l'Abbaye, 134 , B-4040 Herstal- Belgium
Tel +32(0)4 248 39 83 Fax +32(0)4 264 82 38 E-Mail info@buzon.eu

www.buzon.eu

Ref: PB Building Merchant Retailer Tariff - 01/02/2014

BUZON PB-Series® - Technical data sheet PB-5

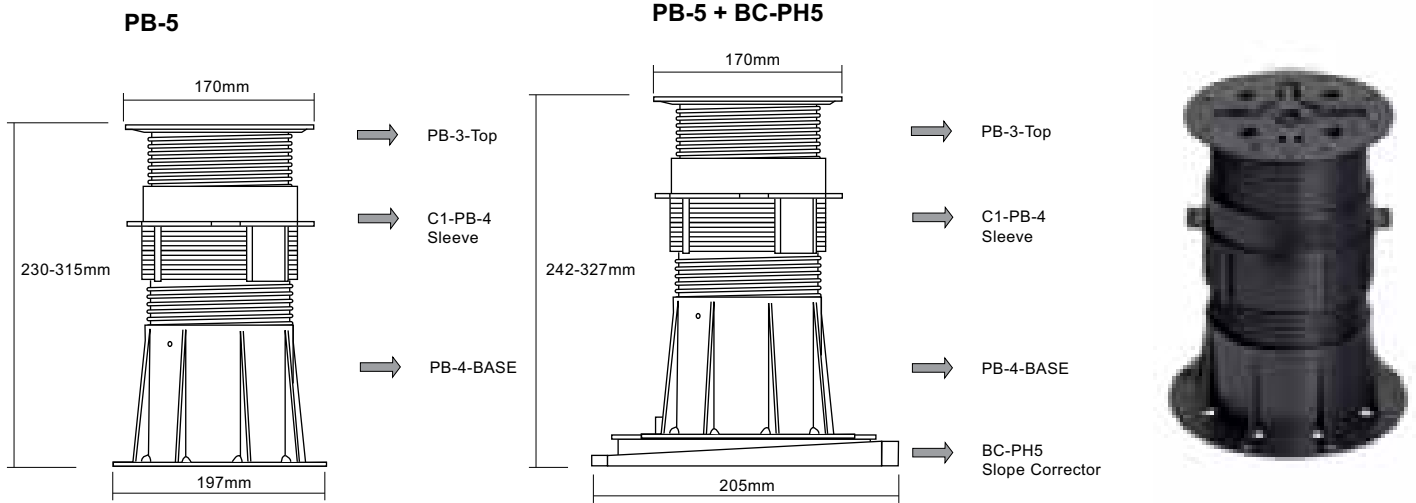

Adjustable height

Adjustable height from 230 to 315mm uninterrupted.
With addition of a 0 to 5% BC-PH5 slope corrector, adjustable from 242 to 327mm

Material

Copolymer polypropylene (CPP), material thickness 3 to 4.5mm
Composition: 80% recycled PPC, 20% talc + UV black masterbatch and 100% recyclable.

Dimensions of the PB-5 pedestal

Top = diameter 170mm – Surface area 227cm²
Base = diameter 197mm – Ground surface 305cm²
Sleeve = diameter 131mm – Height 143.5mm (Qty = 1x)

Performances

Resisting UV light, weather, sea salt and almost all chemicals
Temperature range: -30° to + 90°

Applications

Support for outdoor terraces with any kind of materials: timber decking, stone, ceramic, composite materials, metal, fiberglass grid...Can be placed on any stable substrate, also over insulation panels.

Slope corrector BC-PH-5 from 0 to 5%

Slope corrector B C-PH5 is placed under the base of pedestal PB-5. Consisting of 2 cylindrical parts, it allows to compensate for 1 to 5% slopes by simply rotating the devices.
Thickness of BC-PH-5 = + 12 mm to be added to the adjustable height of pedestal PB-5.



Accessories

Different BUZON accessories can be clipped to the head of pedestal PB-5 according to the materials used by manufacturers of terraces, podiums and temporary exhibitions (pedestals, gratings, tiles, etc.) and other parts for specific applications demanded by manufacturers.

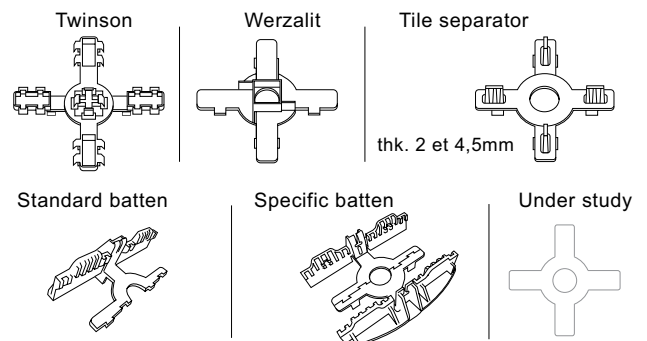

Compression test (1daN = 1Kg/f = 2,23lbf)

Performed on the full (1/1), half (1/2) or quarter (1/4) surface of the head.

Position	Height(mm)	Breaking load(daN)	Breaking load(lbf)
1/1	315	1037	2312
1/2	315	968	2159
1/4	315	707	1576

Important note :

Safety value for maximum allowable load by compression for PB-5:
a) Safety for pedestrian terraces: divide the load indicated in the table by 2 with a safety factor of - 15 %.
(1037kg / 2 = 519kg – 15% = 441 kg acceptable on position 1/1)
b) Safety for technical floors: divide the load indicated in the table by 4 with a safety factor of - 15 %.
(1037kg : 4 = 259kg – 15% = 220 kg acceptable on position 1/1)
Note : The BUZON PB-5 pedestals in polypropylene are not designed to support machinery or equipment subject to vibration.



BUZON® PB-Serie

The PB-Series BUZON pedestals are characterised by their universal head which is capable of supporting all type of materials thanks to the availability of especially designed accessory kits



ACCESSORIES

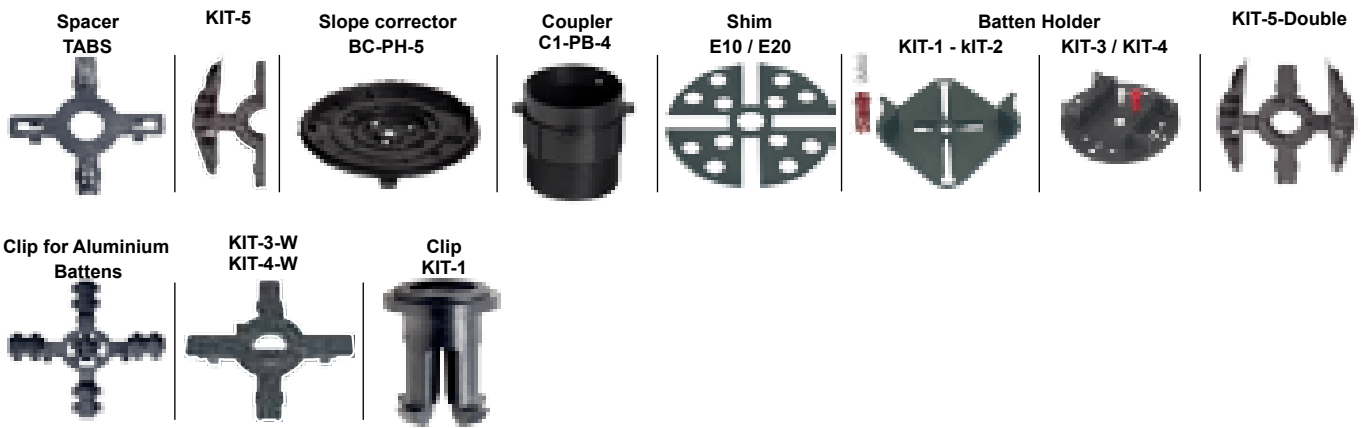

BUZON PB-Series®

TARIFF Code 3000

Sold per unit or per full carton

Prices in Euros, excl. VAT

Code	Height	Price
PB-01	28-42mm	2.45 €

Screwed pedestal - Weight **232g**



28-42mm

Items/carton
78



Carton dim.: **59x40x38cm**
Weight carton alone: **1000g**
Weight carton + items: **19kg**

Cartons/pallet	Items/pallet
25	1950



Gross weight: **490kg**
Net weight: **452kg**
Pallet dim.: **100x120x224cm**
Empty pallet weight: **15kg 100X120X15cm**

Code	Height	Price
PB-1	42-60mm	2.80 €

Screwed pedestal - Weight **309g**



42-60mm

Items/carton
48



Carton dim.: **59x40x38cm**
Weight carton alone: **1000g**
Weight carton + items: **16kg**

Cartons/pallet	Items/pallet
25	1200



Gross weight: **415kg**
Net weight: **370kg**
Pallet dim.: **100x120x224cm**
Empty pallet weight: **15kg 100X120X15cm**

Code	Height	Price
PB-2	60-90mm	3.30 €

Screwed pedestal - Weight **389g**



60-90mm

Items/carton
36



Carton dim.: **59x40x38cm**
Weight carton alone: **1000g**
Weight carton + items: **15kg**

Cartons/pallet	Items/pallet
25	900



Gross weight: **390kg**
Net weight: **350kg**
Pallet dim.: **100x120x200cm**
Empty pallet weight: **15kg 100X120X15cm**

Code	Height	Price
PB-3	90-145mm	4.15 €

Screwed pedestal - Weight **492g**



90-145mm

Items/carton
24



Carton dim.: **50x40x38cm**
Weight carton alone: **1000g**
Weight carton + items: **13kg**

Cartons/pallet	Items/pallet
25	600



Gross weight: **340kg**
Net weight: **295kg**
Pallet dim.: **100x120x200cm**
Empty pallet weight: **15kg 100X120X15cm**

Code	Height	Price
PB-4	145-245mm	5.75 €

Screwed pedestal - Weight **690g**



145-245mm

Items/carton
18



Carton dim.: **60x40x60cm**
Weight carton alone: **1120g**
Weight carton + items: **14kg**

Cartons/pallet	Items/pallet
15	270



Gross weight: **225kg**
Net weight: **186kg**
Pallet dim.: **100x120x200cm**
Empty pallet weight: **15kg 100X120X15cm**



Ref: PB Building Merchant Retailer Tariff - 01/02/2014 Prices are valid for the day and vary as a function of increases in the prices of salaries, social charges and raw materials. General Conditions of Sale pages 13 & 14. © COPYRIGHT

BUZON® PB-Serie

Accessories

Sold per unit or per full carton

Prices in Euros, excl. VAT

Code	Price
PB-4-TOP	2.75 €



Items/carton
24



Carton dim.: **59x41x46cm**
 Weight carton alone: **1120g**
 Weight carton + items: **9kg**

Cartons/pallet
25

Items/pallet
600



Gross weight: **240kg**
 Net weight: **197kg**
 Pallet dim.: **100x120x240cm**
 Empty pallet weight: **15kg 100X120X15cm**

Code	Price
PB-4-BASE	3.00 €

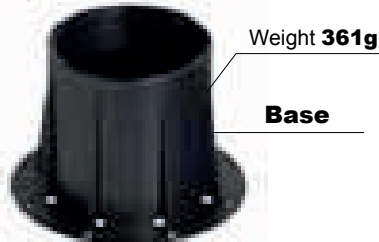

Items/carton
24



Carton dim.: **59x41x46cm**
 Weight carton alone: **1120g**
 Weight carton + items: **10kg**

Cartons/pallet
25

Items/pallet
600



Gross weight: **265kg**
 Net weight: **217kg**
 Pallet dim.: **100x120x240cm**
 Empty pallet weight: **15kg 100X120X15cm**

Code	Price
PB-3-TOP	2.05 €

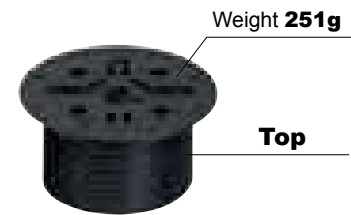

Rem: Only for PB-5

Items/carton
24



Carton dim.: **59x41x30cm**
 Weight carton alone: **996g**
 Weight carton + items: **8kg**

Cartons/pallet
25

Items/pallet
600



Gross weight: **215kg**
 Net weight: **151kg**
 Pallet dim.: **100x120x200cm**
 Empty pallet weight: **15kg 100X120X15cm**

Code	Price
C1-PB-4	2.50 €

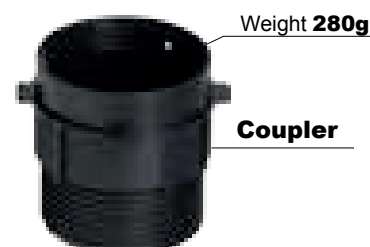

Items/carton
24



Carton dim.: **60x40x45cm**
 Weight carton alone: **1120g**
 Weight carton + items: **8kg**

Cartons/pallet
25

Items/pallet
600



Gross weight: **215kg**
 Net weight: **168kg**
 Pallet dim.: **100x120x240cm**
 Empty pallet weight: **15kg 100X120X15cm**



BUZON PB-Series®

TARIFF Code 3000

Sold per unit or per full carton

Prices in Euros, excl. VAT

Code	Height	Price
PB-5-NSC	230-315mm	7.55 €



230-315mm Weight 892g



PB3-TOP
1 carton X 24 items



C1-PB-4
1 carton X 24 items



PB-4-BASE
1 carton X 24 items

NSC = Non-screwed pedestal

Items/carton
24

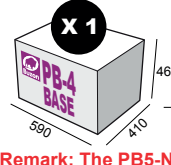
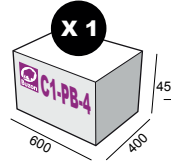
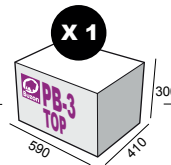

Carton and pallet features see p.5: **PB-3-TOP**



Cartons/pallet	25
Items/pallet	600

Carton and pallet features see p.5: **C1-PB-4**



Cartons/pallet	25
Items/pallet	600

Carton and pallet features see p.5: **PB-4-BASE**



Cartons/pallet	25
Items/pallet	600

Remark: The PB5-NSC pallet may consist of boxes of different items.

Code	Height	Price
PB-6-NSC	285-367mm	8.25 €



285-367mm Weight 970g



PB4-TOP
1 carton X 24 items



C1-PB-4
1 carton X 24 items



PB-4-BASE
1 carton X 24 items

NSC = Non-screwed pedestal

Items/carton
24

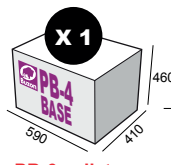
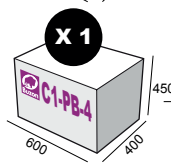
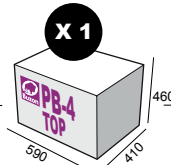

Carton and pallet features see p.5: **PB-4-TOP**



Cartons/pallet	25
Items/pallet	600

Carton and pallet features see p.5: **C1-PB-4**



Cartons/pallet	25
Items/pallet	600

Carton and pallet features see p.5: **PB-4-BASE**



Cartons/pallet	25
Items/pallet	600

Remark: The PB-6 pallet may consist of boxes of different items.

Code	Height	Price
PB-7-NSC	365-485mm	10.75 €



365-485mm Weight 1250g



PB4-TOP
1 carton X 24 items



X 2

C1-PB-4
2 cartons X 24 items



PB-4-BASE
1 carton X 24 items

NSC = Non-screwed pedestal

Items/carton
24

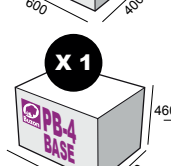
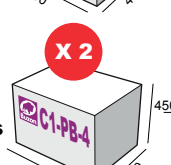
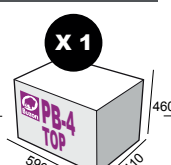

Carton and pallet features: see page 5: **PB-4-TOP**



Cartons/pallet	25
Items/pallet	600

Carton and pallet features: see page 5: **C1-PB-4**



Cartons/pallet	25
Items/pallet	600

Carton and pallet features: see page 5: **PB-4-BASE**



Cartons/pallet	25
Items/pallet	600

Remark: The PB-7 pallet may consist of boxes of different items.



BUZON PB-Series®

TARIFF Code 3000

Sold per unit or per full carton

Prices in Euros, excl. VAT

Code	Height	Price	Items/carton
PB-8-NSC	452-605mm	13,25 €	24

PB4-TOP
1 carton X 24 items

C1-PB-4 3 cartons X 24 items

PB-4-BASE
1 carton X 24 items

PB-4-TOP X 1
460 x 590 x 410

C1-PB-4 X 3
450 x 600 x 400

PB-4-BASE X 1
460 x 590 x 410

Carton and pallet features:
see page 5: **PB-4-TOP**

Cartons/pallet	25
Items/pallet	600

Carton and pallet features:
see page 5: **C1-PB-4**

Cartons/pallet	25
Items/pallet	600

Carton and pallet features:
see page 5: **PB-4-BASE**

Cartons/pallet	25
Items/pallet	600

452-605mm Weight **1530g** **NSC = Non-screwed pedestal** Remark: The PB-8 pallet may consist of boxes of different items.

Code	Height	Price	Items/carton
PB-9-NSC	537-725mm	15,75 €	24

PB4-TOP
1 carton X 24 items

C1-PB-4 4 cartons X 24 items

PB-4-BASE
1 carton X 24 items

PB-4-TOP X 1
460 x 590 x 410

C1-PB-4 X 4
450 x 600 x 400

PB-4-BASE X 1
460 x 590 x 410

Carton and pallet features:
see page 5: **PB-4-TOP**

Cartons/pallet	25
Items/pallet	600

Carton and pallet features:
see page 5: **C1-PB-4**

Cartons/pallet	25
Items/pallet	600

Carton and pallet features:
see page 5: **PB-4-BASE**

Cartons/pallet	25
Items/pallet	600

537-725mm Weight **1810g** **NSC = Non-screwed pedestal** Remark: The PB-9 pallet may consist of boxes of different items.



BUZON PB-Series®

TARIFF Code 3000

Sold per unit or per full carton

Prices in Euros, excl. VAT

Code	Height	Price	Items/carton
PB-10-NSC	620-845mm	18.25€	24

Carton and pallet features: see page 5: **PB-4-TOP**

Cartons/pallet	25
Items/pallet	600

Carton and pallet features: see page 5: **C1-PB-4**

Cartons/pallet	25
Items/pallet	600

Carton and pallet features: see page 5: **PB-4-BASE**

Cartons/pallet	25
Items/pallet	600

620-845mm
Weight **2090g** **Non-screwed pedestal** **Remark: The PB-10 pallet may consist of boxes of different items.**

Code	Height	Price	Items/carton
PB-11-NSC	705-965mm	20.75€	24

Carton and pallet features: see page 5: **PB-4-TOP**

Cartons/pallet	25
Items/pallet	600

Carton and pallet features: see page 5: **C1-PB-4**

Cartons/pallet	25
Items/pallet	600

Carton and pallet features: see page 5: **PB-4-BASE**

Cartons/pallet	25
Items/pallet	600

705-965mm
Weight **2370g** **Non-screwed pedestal** **Remark: The PB-11 pallet may consist of boxes of different items.**



BUZON® PB-Serie

Accessories

Sold per unit or per full carton

Prices in Euros, excl. VAT

Code	Tab width	Price
PB-TABS-2	2mm	0,35€
PB-TABS-3	3mm	0,35€
PB-TABS-4.5	4.5mm	0,40€

Tile support tabs

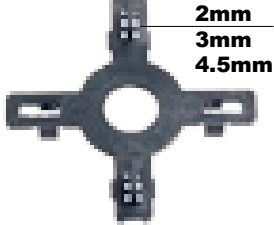

Weight 2mm **16g** / 3mm **16,5g** / 4.5mm **17g**

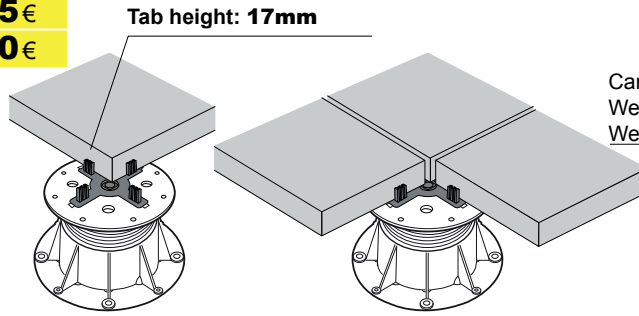
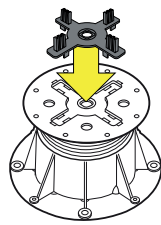

Items/carton
120
120
120

Carton dim.: **40x29x20**
Weight carton alone: **300g**
Weight carton + items: **2kg**

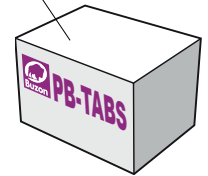

Code	Type	Price
PB-CLIP-KIT-5	SIMPLE	0,80€

Clip for timber joists of different dimensions



Weight **40g**

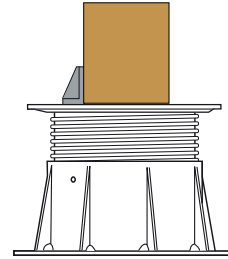
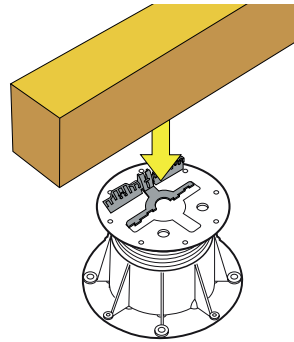
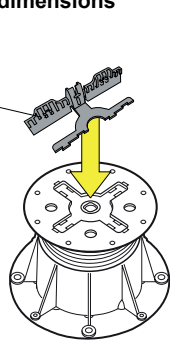

Carton dim.: **40x29x20**
Weight carton alone: **300g**
Weight carton + items: **2.2Kg**

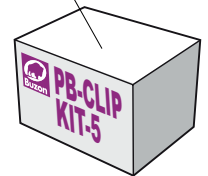

Code	Height	Price
BC-PH-5	12mm	2,05€

Slope corrector 0 to 5%



Weight **194g**

Remark: Thickness = 12mm to add at adjustable pedestals

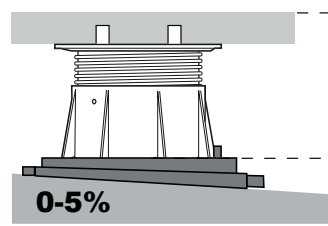
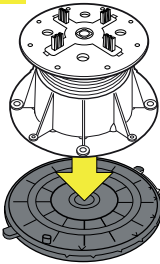

Carton dim.: **47x47x44**
Weight carton alone: **1100g**
Weight carton + items: **17kg**

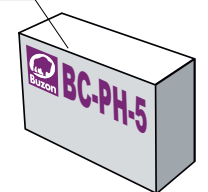

Code	Thickness	Price
BC-E10	1mm	0,30€
BC-E20	2mm	0,45€

Items/carton
1mm: 500
2mm: 250

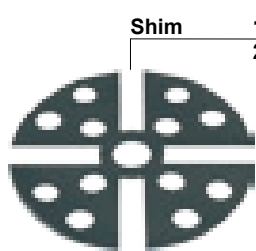

Weight: 1mm: **23gr**
2mm: **40gr**

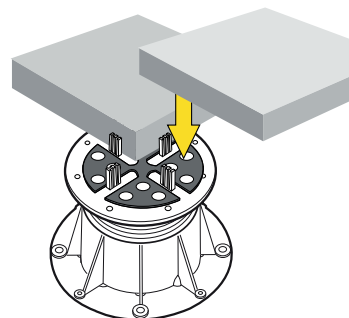
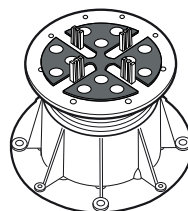
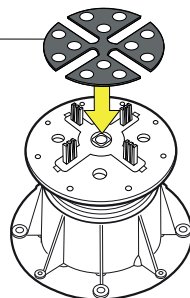

1mm
Carton dim.: **40x29x20**
Weight carton alone: **400g**
Weight carton + items: **8kg**



2mm
Carton dim.: **40x29x20**
Weight carton alone: **400g**
Weight carton + items: **8kg**



BUZON® PB-Serie

Accessories

Sold per unit or per full carton

Prices in Euros, excl. VAT

Code	Price
PB-CLIP-KIT-1	0,15€

Items/carton	3240
Items/bag	120

Attachment plug

For tiles

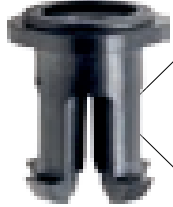

For fixing of pipes

Poids **2gr**

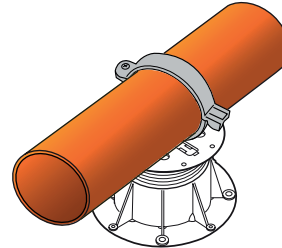
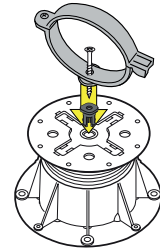
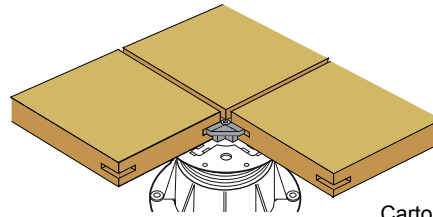
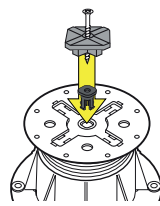

Carton dim.: **60x29x20**
Weight carton alone: **...g**
Weight carton + items: **...g**



Code	Prix
PB-CLIP-KIT-2	0,40€

Items/carton	60
--------------	-----------

Clips for aluminium battens

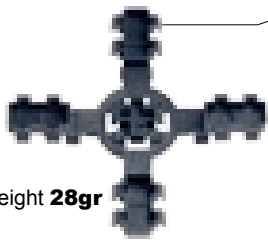

Weight **28gr**

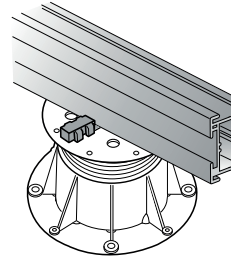
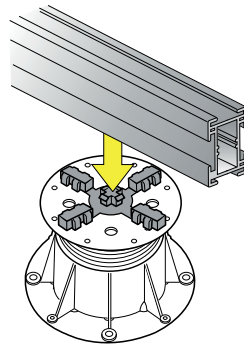
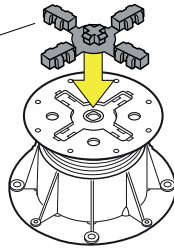

Carton dim.: **40x29x20**
Weight carton alone: **300g**
Weight carton + items: **2kg**



Code	Type	Price
PB-CLIP-KIT-3	Central	0,40€

Items/carton	72
--------------	-----------

Clip for tiles
Central installation



Weight **20gr**

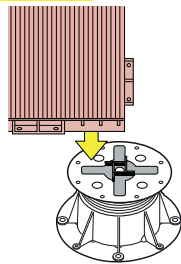
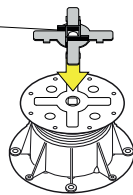

Tile dim.: **439x439mm**

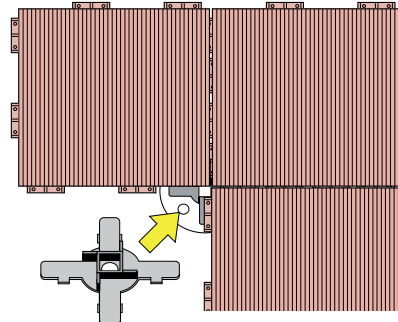

Carton dim.: **40x29x20**
Weight carton alone: **300g**
Weight carton + items: **1.5kg**



Code	Type	Price
PB-CLIP-KIT-4	EDGE WALL	0,40€

Items/carton	72
--------------	-----------

Clip for tiles
Installation along wall



Weight **19gr**

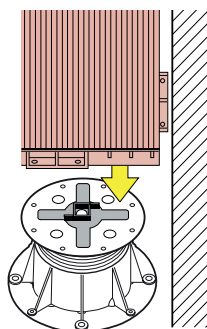
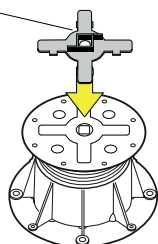

Tile dim.: **439x439mm** Wall

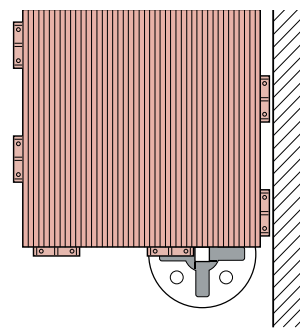

Carton dim.: **40x29x20**
Weight carton alone: **300g**
Weight carton + items: **1.5kg**



BUZON® PB-Serie

Accessories

Sold per unit or per full carton

Prices in Euros, excl. VAT

Code	Type
PB-CLIP-KIT-5	DOUBLE

Clip for timber joists with specific dimensions

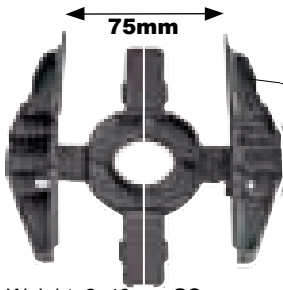

Weight: 2x40g = **80g**

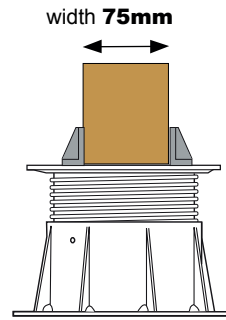
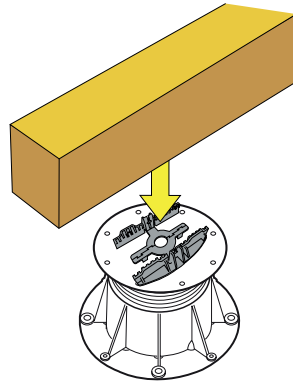
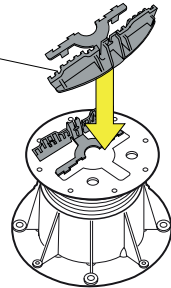

Code	Type	Price	Items/carton
BC-BATTEN-KIT-2	RACK PLUG MEDIUM	2,10€	120

Pin Tube
x1

Rack Plug
MEDIUM
X1

Guide Batten
X2

BC-Batten
X1

Weight: **125gr**

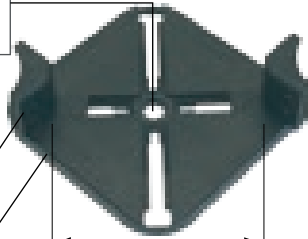

Adjustable from **35 to 90mm**

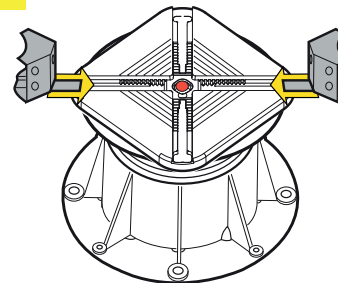

Carton dim.: **52x35x31**
Weight carton alone: **700g**
Weight carton + items: **16kg**

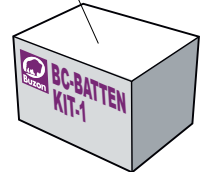

Remark: Thickness = 11mm to add at adjustable pedestals

Code	Type	Price
BC-GUIDE-BATTEN	Guide	0,35€



Weight: **12gr**

2 additional guides may be added on the BC-BATTEN in the case of using 3 battens

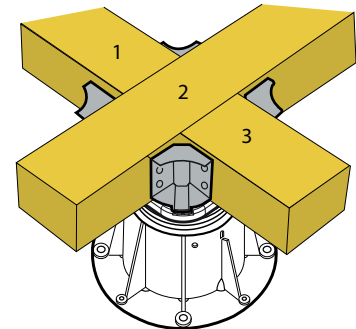
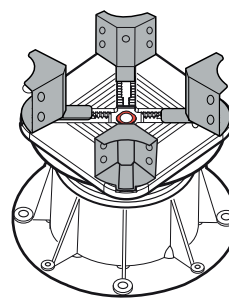

Code	Type	Price
KIT-3-DPH	65mm	1,35€

Weight: **96gr**



KIT-3
Rack Plug Medium
h:20mm

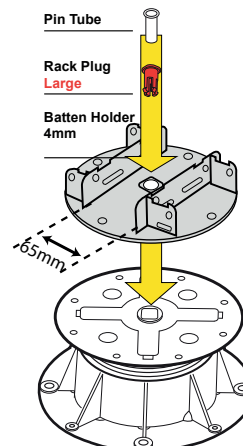

Items/carton
120

Carton dim.: **52x35x41**
Weight carton alone: **1000g**
Weight carton + items: **12kg**

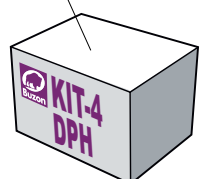

BUZON® PB-Serie

Accessories

Sold per unit or per full carton

Prices in Euros, excl. VAT

Code	Type	Price
KEY-BC-DPH-PB	BPI	6,45€



Weight: **56 gr**

Key in Polyamide
Adjust simply the height of Buzon pedestals

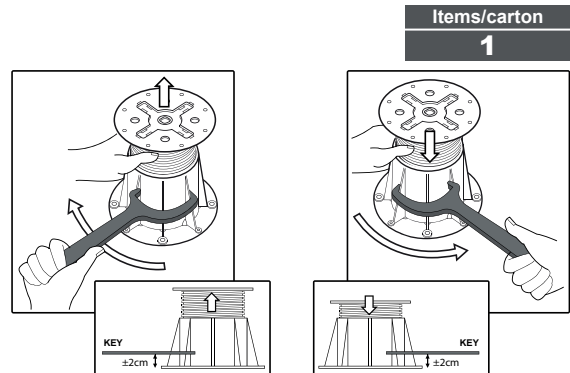

Items/carton
1

Code	Type	Price
KIT SL 80	BPI	44,60€

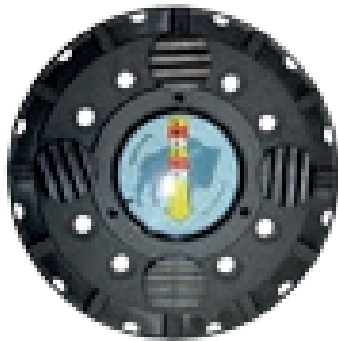

Weight: **315 gr**

BUZON LEVEL
Determine the value (%) and the direction of the slope
KIT composition :

- Buzon level
- BC-0-PP-SA-NA pedestal
- Yellow chalk 'PELIKAN'
- 4 fixation clips
- Instructions (AIP)

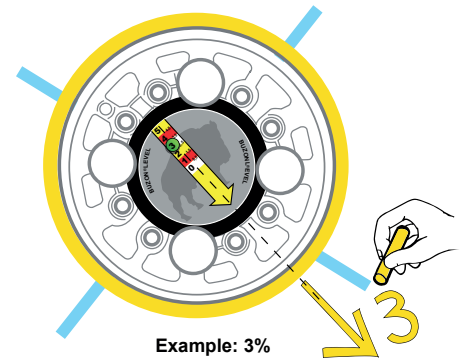

Items/carton
1

Code	Type	Price
GRIP LIFTING	BPI	27,65€



Weight: **1222 gr**

Dimensions of paving stones in cm

30 x 30	35 x 35	40 x 40
45 x 45	49 x 49	50 x 50

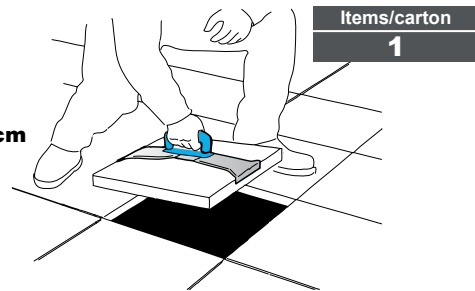

Items/carton
1

GENERAL CONDITIONS OF SALE INTERNATIONAL

I. General provisions

1.1. These general terms and conditions apply to all contracts concluded by BUZON Pedestal International (abbreviated into "BPI") SA (hereinafter « the Company ») regarding the sale of paving supports for terraces.

1.2. The acceptance of an order or a quote by a customer, the signing of an agreement or of a purchase order entails his/her/its full and entire acceptance of these general terms and conditions and, unless any provision to the contrary which has been the subject of a specific and prior written agreement, his/her/its waiver to rely on his/her/its own specific and general terms and conditions mentioned in his/her/its own purchase orders, invoices, letters or business documents whatsoever, even if such documents were previously established. The purchaser expressly waives them by proceeding with the order set out in this document.

1.3. Only the exemptions agreed upon in writing by the Company can modify the application of these general terms and conditions.

Moreover, all clauses in any correspondence or other documents issued by the purchaser in any capacity whatsoever and which would be contrary to these general terms and conditions will be considered null and void absent the Company's prior and express written approval thereof.

1.4 BPI and the purchaser agree that, as of their first agreement under these terms and conditions, such terms and conditions shall fully apply to all their later transactions.

II. Validity of offers

Unless any contrary written provisions, the period of validity of our offers is 10 days from the date of their issuance.

III. Orders

3.1. All orders will be firm and final and will be binding to both parties upon signature by the customer of a purchase order accepted by the Company. The changes made by the customer to the offer or to the purchase order shall only be valid if the Company has accepted and confirmed them in writing.

3.2. The cancellation of an order must be done in writing, prior to the shipment of the goods and it is only valid after BPI's written acceptance.

In the event of such a cancellation by the customer, the Company reserves the right to claim a compensation of 30% of the total amount of the order.

IV. Timing

4.1. For intra-European Union deliveries, the deadlines for the supply of the ordered goods, services or deliveries are 5 to 10 days from the date of receipt of the payment. For deliveries outside of the European Union, the deadlines shall be determined for each order.

4.2. In principle, these terms are not binding but are given as an indication.

A delay in delivery can therefore in no event give entitlement to the allowance of any damages or compensation, nor to the termination of the agreement.

4.3. If the purchase order expressly states a binding deadline which is an essential condition of the agreement, this deadline must have been expressly accepted by BPI. Any exceedance of the term by the Company can give rise to a maximum indemnity of 15% of the amount of the order only if a notice by the customer sent by registered letter has remained without effect during 15 days after its sending date and if the customer proves that he has suffered damage as a result of the exceedance of the term. Even so, the following circumstances (non-exhaustive list) release the Company from the binding deadline: the situations of force majeure or circumstances beyond its control, the customer's violation of terms of payment, changes decided by the customer during operation, the customer's failure to transmit requested information and any other violation of this contract by the customer.

V. Delivery – Transport

5.1. The goods are made available to the customer at the Company's place of business, as indicated on the order form.

5.2. Goods carried by the customer or delivered by the care of the Company or of a carrier travel at the expense and risk of the customer (Ex work). Their condition, quality and quantity must be verified by the customer upon collection or delivery which counts as full approval of said goods.

To be valid, any complaint must be addressed to the Company by registered letter within 8 days after receipt of the goods.

The goods cannot be returned or exchanged.

5.3. If the purchaser fails or refuses to take delivery of ordered goods, the Company reserves the right to claim the performance of the contract or, after a formal prior notice, to consider the contract terminated as of right. In the latter case, the purchaser shall be liable, as of right and within eight days after the notification of this termination, to pay a lump sum indemnity of up to 30% of the selling price.

VI. Reservation of title

6.1. The Company retains ownership of the goods sold until full payment of the price and its accessories (any costs, interests and penalties). As a consequence, the purchaser expressly undertakes not to sell, assign, pledge and generally alienate the goods subject to the agreement prior to clearance of his/her/its account.

The purchaser nevertheless remains solely responsible for the loss, even by fortuitous event or force majeure, of the goods sold.

6.2. The purchaser shall notify the Company if the goods are stored in a room rented by the customer. He/She/It will communicate the identity and the address of the owner of the concerned building.

The purchaser is also obliged to oppose any seizure, whether conservatory or enforceable, to immediately notify the reservation of title to the seizing party and to inform the Company thereof within 24 hours of becoming aware of the seizure, under penalty of being held liable.

In any event, as long as the purchaser has not fulfilled all his/her/its obligations, he/she/it is obliged to keep the goods delivered by BPI separately from other goods and to clearly identify them as the property of the Company, as well as to adequately insure them.

6.3. In case of non-payment on the due date, the Company is authorized to enforce its property rights at any time, and to immediately retake possession of the goods at the purchaser's expense. The amounts already paid will remain acquired by the Company by way of compensation, without prejudice to the Company's right to claim the entirety of its damage.

VII. Price

The prices are quoted in EURO (€) and exclude VAT, any other taxes or charges which are at all times borne by the purchaser, except as otherwise expressly specified in the offers and/or order confirmations.

The prices indicated by the Company are based on the economic conditions that existed at the time of the offer, such as the prices set by the suppliers, transport conditions, the availability of goods, the present value of the wages, social laws and materials. Any significant changes in these conditions may result in changes of the prices set. In this case, the Company shall notify the purchaser in writing of the price adjustment at least 5 days before the scheduled delivery date. If the purchaser does not object to this change within 48 hours, the new price shall be considered to have been accepted by the purchaser and to be binding to the parties. If, within this period, the purchaser objects to the price increase, the Company can decide to continue to supply the goods at the initially set price or to resolve the order, without compensation, within 24 hours after the purchaser's objection.

VIII. Payment

8.1. The invoices are payable in EURO (€) by SWIFT transfer only, minus a 3% discount if paid in cash.

After this period, any unpaid invoice shall automatically and without prior notice yield a conventional interest of 12% per year.

Any invoice not paid at the due date shall automatically and upon prior notice be further increased with an irreducible lump sum indemnity of 15% of the amount remaining unpaid with a minimum of 50 € per invoice.

Any dispute relating to an invoice must reach the Company in writing within 8 days of receipt of the invoice.



GENERAL CONDITIONS OF SALE INTERNATIONAL

8.2. In case of non-payment of one single invoice at its due date, all other invoices issued but not yet due shall immediately and automatically become due. When a particular payment term was granted, the non-payment of an invoice at one of the contractually provided due dates or the failure to comply with special conditions granted, shall, without prior notice, lead to the revocation of the special conditions for payment.

When the purchaser's credit deteriorates, in particular if judicial enforcement measures are taken against him/her/it and/or in case of events that question the proper performance of commitments made or render this impossible, the Company reserves the right, even after partial execution of an order, to require the purchaser to provide the additional guarantees it considers appropriate with a view to the proper performance of both parties' commitments. If the purchaser refuses to comply with this requirement, the Company is entitled to terminate the agreement and to cancel the complete order or part thereof.

IX. Financing

Any financing by the purchaser to acquire the goods must be expressly stated in the order form.

X. Guarantee

10.1. In the absence of written notification, the purchaser is deemed to have accepted the goods within 8 days of delivery.

The approval will cover any apparent defects and lacks of conformity, that is to say all defects that the purchaser can detect at the time of the delivery. Hidden defects must be reported by the purchaser within 8 days of their discovery, however, this period cannot exceed 3 months from the delivery.

On pain of nullity, any legal actions must be brought within one year after notification of the claim.

10.2. Standards or quality requirements of the goods delivered by BPI are known to the purchaser. The Company's obligation to provide a guarantee does not extend beyond the quality requirements or quality standards that are specified therein.

10.3. The purchaser is responsible for ensuring the maintenance, protection and proper use of the delivered equipment and in particular to avoid any moisture problem. The Company can in no event be held liable for defects and flaws that would affect the goods and would result from storage, installation, implementation or improper use, etc. of the part of the purchaser.

In any event, the guarantee of BPI does not apply when (non-exhaustive list):

- a. The purchaser has not fulfilled all his/her/it obligations vis-à-vis BPI ;
- b. The goods are exposed to unusual circumstances or are treated in a negligent or incompetent manner;
- c. The goods are stored for longer than required or are inadequately stored, in such a way that a loss of quality is likely to ensue ;
- d. The purchaser has ignored and/or failed to comply with installation, maintenance or other guidelines;
- e. The Company has not been authorized to examine the defect within 8 working days of its discovery;
- f. A period of 3 months has lapsed since delivery.

10.4. The Company guarantees the products it sells when the abovementioned conditions are not met and, moreover, the purchaser provides the Company with a photographic record of the site before, during and after the installation of the goods supplied by BPI. This record must show the installation, the correct configuration of the paving supports, their positioning, the installation of the surface coating, etc. to demonstrate that the installation complied with all the recommendations supplied by BPI and with the rules of art.

To invoke the benefit of the guarantee, the purchaser must notify his claim to the Company by registered letter within 15 days of its finding.

The guarantee is limited to the replacement of the defective goods. The purchaser is obliged to keep the defective goods at BPI's disposal. The purchaser shall in no event be discharged from his/her/its obligation to pay the litigious goods.

10.5. The installation guidelines as well as the resistance and compression tests of the goods are well known to the purchaser. This information is, amongst others, included in the BINDER which is an integral part of these general terms and conditions of sale, and which the purchaser acknowledges to have been aware of. In any event, the goods can only be guaranteed for the use that the Company created them for.

XI. Force Majeure

Fortuitous or force majeure events entitle the Company to suspend the execution of all or part of its obligations and/or to terminate the contract, partially or completely, without being due any compensation.

Are considered as force majeure events: strikes, lockouts, wars, riots, irregularities or lack of means of transportation, shortage of materials, weather, floods and any element beyond the Company's control that has the effect of totally or partially decelerating or interrupting its deliveries.

XII. Competition – Intellectual property

The studies, designs, samples, plans, photographs,... from the Company remain its property and cannot be copied or reproduced. They must be returned at the Company's first request and cannot be communicated to a third party for any reason whatsoever, without the Company's prior consent.

Furthermore, the purchaser recognizes the validity of the totality of the intellectual property rights held by BPI (patents, trademarks,...) and undertakes not to infringe upon such rights, whether directly or indirectly, in any manner. Otherwise, the purchaser shall be liable to pay an immediate and incompressible compensation of 50,000 €, without prejudice to any additional claim brought by the Company.

XIII. Disputes

13.1. Any dispute regarding the interpretation or the performance of the obligations following from the order and the application of the general terms and conditions of sale is governed by and construed in accordance with Belgian law, excluding the provisions of the United Nations Convention on Contracts for the International Sale of Goods done at Vienna on 11 April 1980 and approved by the Belgian law of 4 September 1996. The jurisdiction for these disputes is attributed to the courts of the judicial district of LIEGE (Belgium), without possibility for the purchaser to submit the dispute to another court, even by way of interlocutory application, call in guarantee, action to enforce a warranty or a third party joinder.

13.2. If this version of the general terms and conditions of sale is drafted in a language other than French, the parties agree that the French version will serve as reference in case of problems of interpretation.

XIV. Changes to the agreement

Any change of specific agreements or of these general terms and conditions must be done by a written amendment signed by all parties.

XV. Severability clause

The invalidity or illegality of any clause in the contracts (specific and general terms and conditions) agreed between the parties does in no event cause any invalidity or nullity of other terms and conditions of the agreement concluded between the parties, and these clauses remain fully valid.





Buzon

WORLDWIDE REFERENCES

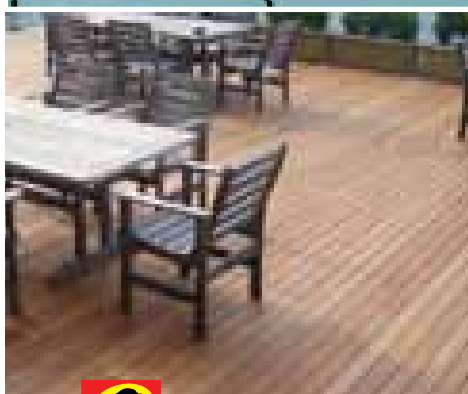
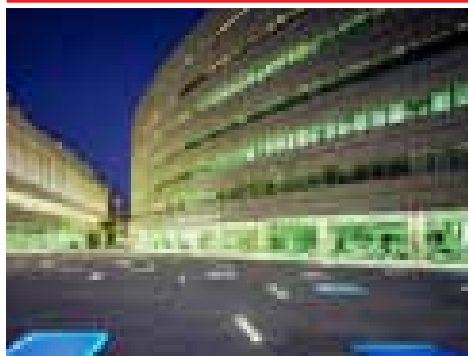

Ref: PB Building Merchant Retailer Tariff - 01/02/2014 Prices are valid for the day and vary as a function of increases in the prices of salaries, social charges and raw materials. General Conditions of Sale pages 13 & 14.

BUZON PB-Series®



PB-Anr/1000/ 01-02-2014



BUZON Pedestal International s.a./n.v
Z.I. des Hauts-Sarts, Zone 1 - Prolongement de la rue de l'Abbaye, 134 , B-4040 Herstal- Belgium
Tel +32(0)4 248 39 83 Fax +32(0)4 264 82 38 E-Mail info@buzon.eu www.buzon.eu